



Potato Handling Solutions

Handling your produce with care...

Over the past four decades Herbert has built an enviable reputation for the design, manufacture and supply of innovative produce handling equipment.

We treasure your roots

At the root of handling systems

Herbert is one of Europe's leading manufacturers of systems for the fresh vegetable packing and processing industries and we maintain that position through continued product development and innovation.

Four decades of know-how

With our many years of experience, we have built up a wealth of knowledge on the gentle and efficient handling of potatoes. We are innovators in the design and build of individual handling equipment right through to complete pack-house installations on green field sites and plant upgrades.

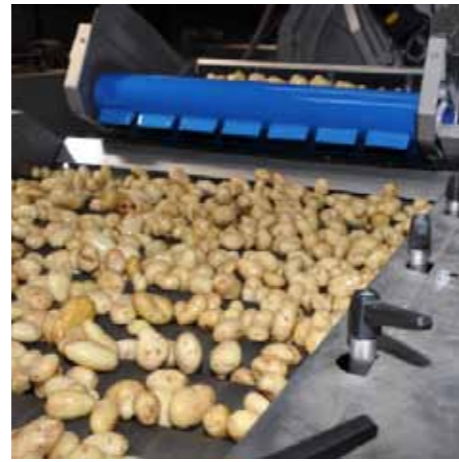

Better quality for your customers and improved productivity for your pack-house

At Herbert, we understand our customers and what they need in order to run their businesses efficiently and profitably. That understanding underpins the way we design and manufacture our equipment and the pre-and after-sales service we provide.

Flexibility

Our machinery is designed to cope with fluctuations in crop quality and soil conditions that can vary from field to field, from day to day and from season to season. We recognise the need for systems that allow total flexibility for packing a whole range of different size bands, varying quality and different finished product formats, from prepack polys and punnets to sacks, nets, and loose trays to satisfy all of your customers demands.

High throughputs and volumes

We build systems that achieve maximum volume throughput and minimum product wastage combined with the lowest possible labour costs.



Gentle product handling

We know how easy it is to cause damage to root vegetables so we design all our equipment to handle crops with the utmost care and with minimal drops to reduce wastage and improve the quality of the finished product.

Reliability

With pack-houses frequently operating seven days a week machine reliability and the availability of service, spares, and on site support are crucial, particularly at times of highest demand like Christmas and Easter. With the need to maintain consistent throughputs and meet the daily expectations of your customers, downtime caused by breakdowns and maintenance has to be minimised. That is why all our handling equipment is built stronger to last longer, its design makes maintenance incredibly quick and simple and cleaning is easy and effective, whilst our after-sales service is always there when it's needed.

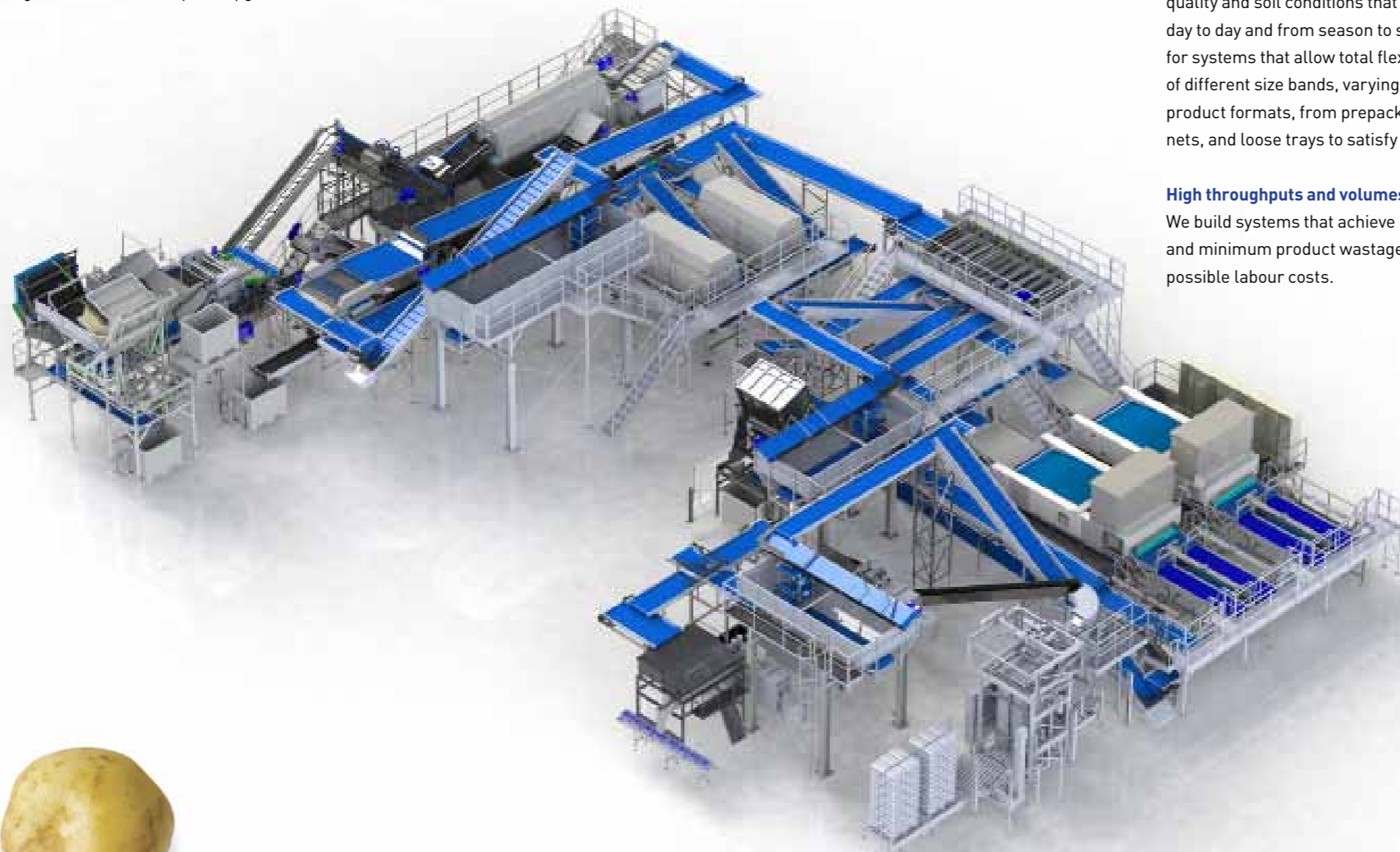



Expertise and reliability from the field to the customer

Herbert's potato systems can handle from 1 tonne up to 40 tonnes per hour via single or multiple lanes. They can be seamlessly integrated with a customer's existing or new weighing and packing equipment, and can accommodate any individual requirements.

A Herbert system will deliver your produce from field to finished product gently, efficiently and cost effectively.



Farm 2400 Mobile Grading System

Compressed graphical representation of a typical line demonstrating the equipment used
All heights and drops are therefore distorted to fit schematic diagram

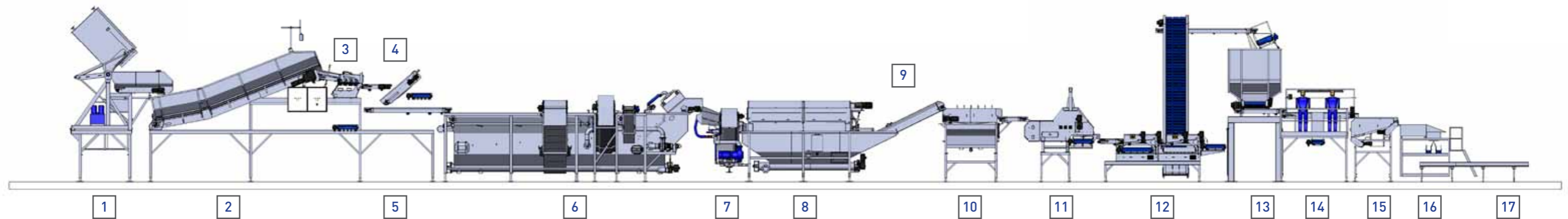

Big bag/box tipper



Intake hopper



Cleaner

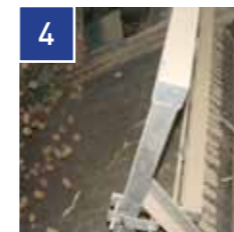

Leaf/top removal



Conveyor



Wet reception tank



De-Stoner



Washer



Elevator



Sponge drier



Oculus
Optical sorting



Grader module

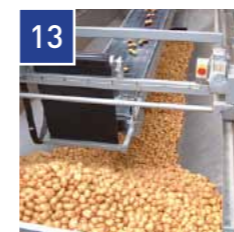

Holding bin



Inspection

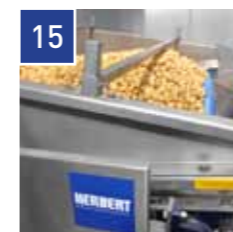

Evenflow hopper



Packing



End of line solutions



What our customers say



Customer Service

Our Technical team are committed to understanding our customers' businesses right from the outset. Throughout the relationship they will endeavour to provide the first class support and after-sales and service care that Herbert are renowned for.

Design

Our experienced team work to these straightforward customer requirements: Increasing output, improving quality, lowering costs and ensuring maintenance and operator friendly features. We invest heavily in Research and Development to keep products up to date and offer customers new industry innovations. Working together our development consultancy can provide solutions to age-old problems and innovative ideas to changing market requirements



Installation

Our experienced and flexible installation team can undertake plant installation in challenging time-sensitive environments. The fully equipped vans enable our team to easily carry out full site services as requested by the customer. Health and Safety documentation is provided to ensure a safe environment for everyone.

Service

Our dedicated team of experienced service engineers provide training, service and repair, offering service options to keep your machinery in optimum working condition and reducing the risk of downtime. We will advise you on the recommended type of service for your machinery, whether it is a stand alone machine or a specifically designed system, and work with you to help ensure that you can meet peaks in demand and are best placed to satisfy your customers' changing demands.

Parts

Herbert's parts department carries a wide range of spares in stock for same day or next day delivery. In addition, our local agent network means that you may be able to get the parts you require from a partner in your local area.

Training and Manuals

Full training is offered to supervisors and key operators of Herbert machinery to ensure effective use of our equipment, and to provide a safe working environment for everyone.



We appointed Herbert Engineering as the main supplier due to their innovative solutions, efficient project management, quality manufacturing facility and excellent pack-house experience. We are delighted with the increased throughputs that we are now achieving as a result of the new system, and the savings we are able to make on labour.

Mike Renouard
Jersey Royal (Potato Marketing) Company



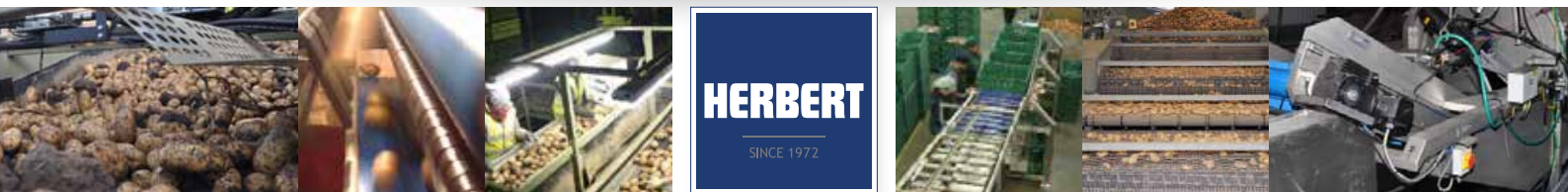

All the ingredients you need to create more value

Herbert is distinctive in the market by entering into dialogue with the industry and by utilising the latest technologies and applications in the field of fresh produce processing and production processes. In addition to the production process, the company focuses on developing optimum solutions to set up processes as efficiently, smartly and profitably as possible.

Herbert provides total concepts. This means that, in addition to Herbert Tailor-Made Solutions, it has scope to supply supplementary specialised equipment through third parties, such as end of line automation and water recycling systems and solutions for the process industry.

Herbert B.V. | Luchthavenweg 99
 NL-5657 EA Eindhoven | The Netherlands
 tel. +31(0) 40 20 10 434
 info@herbertsolutions.com

www.herbertsolutions.com

DESIGN > BUILD > INSTALL > SUPPORT

